

Mirafi® X-Series Woven Polypropylene Geotextiles for Soil Separation

TenCate develops and produces materials that function to increase performance, reduce costs and deliver measurable results by working with our customers to provide advanced solutions.

The Difference Mirafi® X-Series Geotextiles Make:

- **Construction.** Woven slit-film construction offers good resistance to installation abuse.
- **Strength.** High grab tensile and puncture strengths provide good performance in a wide range of roadway applications.
- **Environmental.** Mirafi® X-Series geotextiles are chemically stable in a wide range of aggressive environments.
- **Cost Effective.** Mirafi® X-Series geotextiles provide economical solutions to many civil engineering applications including a cost-effective road base separation layer.

APPLICATIONS

Mirafi® 500X applications include separation under parking lots, residential streets, and roadways. Mirafi® 500X is used over good to moderate strength subgrades for separation of base materials. Mirafi® 500X meets AASHTO M288-06 Specifications for Stabilization and Separation - Class 3.

Mirafi® 600X is used for separation and stabilization over moderate subgrades where coarse, angular, and abrasive base material is required. Mirafi® 600X provides separation and stabilization when moderate loads are expected. Mirafi® 600X meets AASHTO M288-06 Specifications for Stabilization and Separation - Class 1 and 2.

INSTALLATION GUIDELINES*

Geotextile Placement

Place the geosynthetic directly on prepared site. It is advisable to leave vegetative cover such as grass and weeds in place to provide a support matting for construction activities. It should be rolled out flat and tight with no folds. The rolls should be oriented as shown on plans to insure the principal strength direction of the material is placed in the correct orientation. Adjacent rolls should be overlapped or seamed as a function of subgrade strength (CBR).

Prior to fill placement, the geosynthetic should be held in place using suitable means such as pins, soil, staples or sandbags so that it does not move during fill placement.

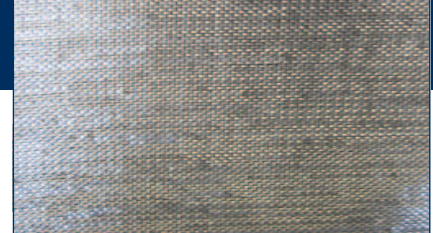

Mirafi® X-Series Woven Polypropylene Geotextiles

Fill Placement

Fill should be placed directly over the geosynthetic in 8in (20cm) to 12in (30cm) loose lifts. For very weak subgrades, 18in (45cm) thicker lifts may be required to stabilize the subgrade, as directed by the engineer.

Typically, vehicles should not be driven on Mirafi® X-Series geotextiles. Tracked construction equipment should not be operated directly upon the geosynthetic. A minimum fill soil thickness of 6in (15cm) is required prior to operation of tracked vehicles over the geosynthetic. Turning of tracked vehicles should be kept to a minimum to prevent tracks from displacing the fill and damaging the geosynthetic.

* These guidelines serve as a general basis for installation. Detailed instructions are available from your TenCate™ representative.



Mirafi® X-Series Woven Polypropylene Geotextiles for Soil Separation

Property	Test Method	Units	500X	600X
Mechanical Properties			Minimum Average Roll Average	
Grab Tensile Strength	ASTM D4632	lbs (N)	200 (890)	315 (1402)
Grab Tensile Elongation	ASTM D4632	% MD / CD	15/15	15/15
Trapezoid Tear Strength	ASTM D4533	lbs (N)	75 (334)	113 (503)
CBR Puncture Strength	ASTM D6241	lbs (N)	700 (3115)	900 (4005)
Hydraulic Properties			Maximum Opening Size	
Apparent Opening Size	ASTM D4751	US Sieve (mm)	40 (0.425)	40 (0.425)
			Minimum Roll Value	
Permittivity	ASTM D4491	sec ⁻¹	0.05	0.05
Flow Rate	ASTM D4491	gal/min/ft ² (l/min/m ²)	4.0 (163)	4.0 (163)
			Minimum Test Value	
UV Resistance after 500 hours	ASTM D4355	% Strength	70	70
Packaging		Units	500X	600X
Roll Width		ft (m)	12.5 (3.8) 15.0 (4.57) 17.5 (5.3)	12.5 (3.8) 15.0 (4.57) 17.5 (5.3)
Roll Length		ft (m)	432 (132) 360 (110) 309 (94.2)	360 (110) 300 (91.44) 258 (78.7)
Roll Area		yd ² (m ²)	600 (502)	500 (418)

Mirafi® X-Series Woven Polypropylene Geotextiles

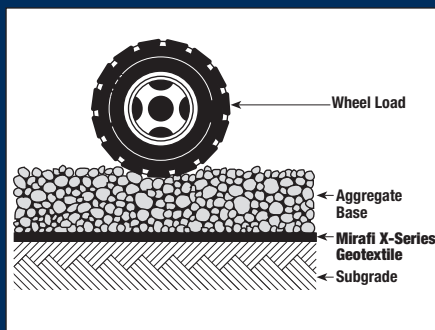

Subgrade/Aggregate Separation

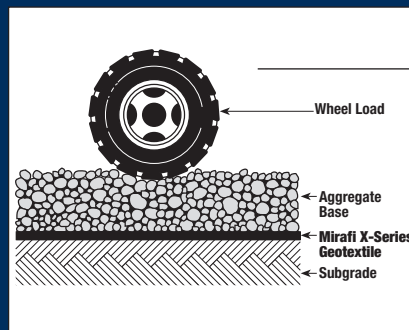

Aggregate Confinement

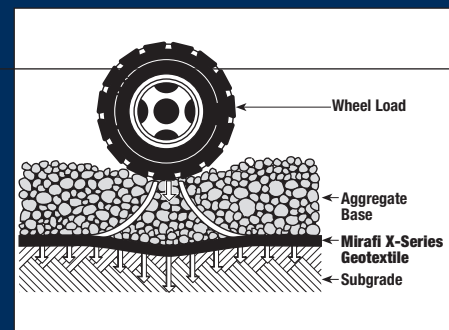

Subgrade Load Distribution

TenCate Geosynthetics Americas assumes no liability for the accuracy or completeness of this information or for the ultimate use by the purchaser. TenCate® Geosynthetics Americas disclaims any and all express, implied, or statutory standards, warranties or guarantees, including without limitation any implied warranty as to merchantability or fitness for a particular purpose or arising from a course of dealing or usage of trade as to any equipment, materials, or information furnished herewith. This document should not be construed as engineering advice.

Mirafi® is a registered trademark of Nicolon Corporation.

© 2016 Nicolon Corporation. All Rights Reserved.

PDS.X0916

365 South Holland Drive Tel 800 685 9990 Fax 706 693 4400
Pendergrass, GA 30567 Tel 706 693 2226 www.mirafi.com



TENCATE
materials that make a difference